

Gru idraulica  
di qualità  
100% Italiana

**OMV 45A**

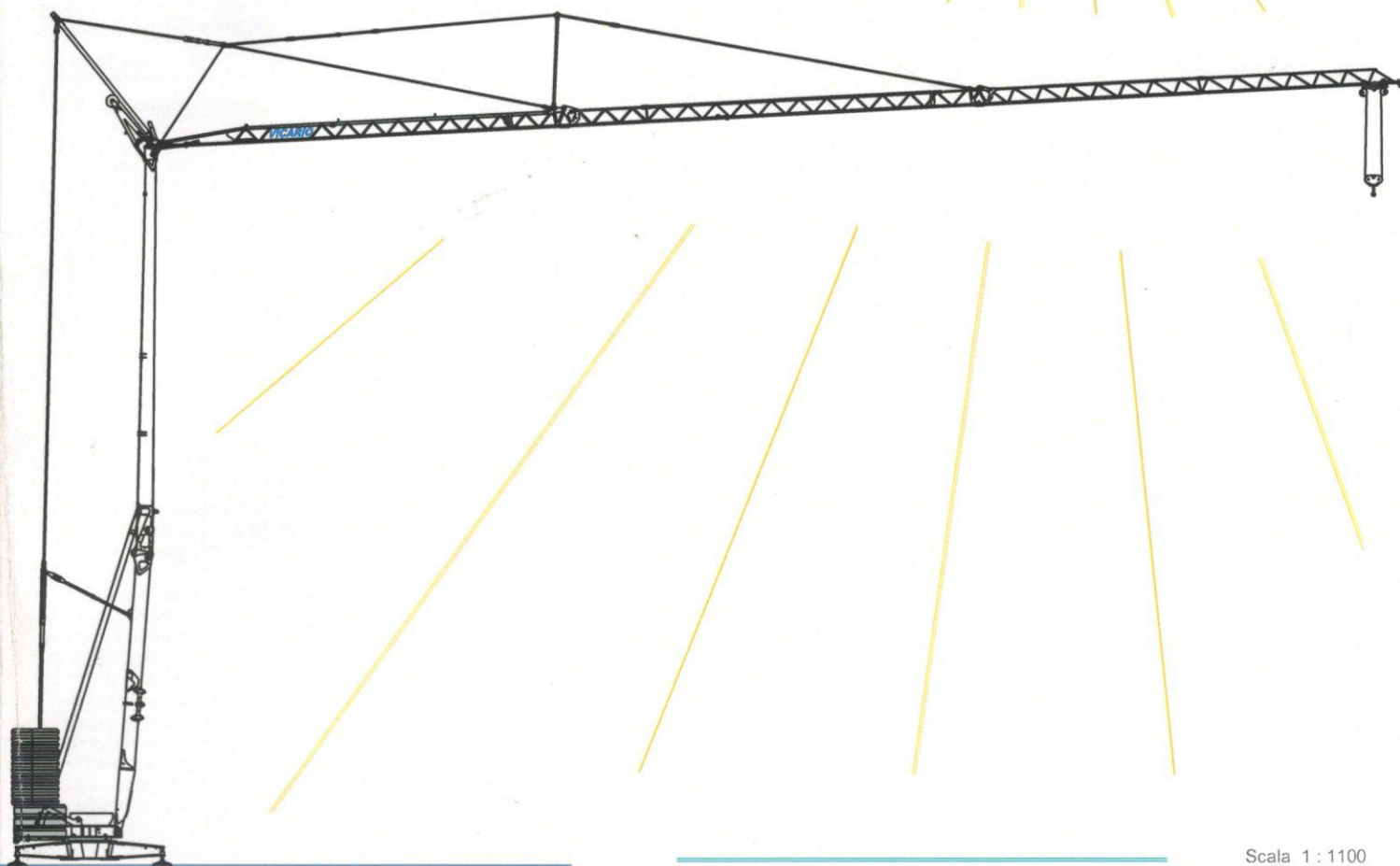

Scala 1 : 1100



una novità delle Officine Meccaniche

Ein neuer VICARIO Kran

A new crane from VICARIO Industries

Une nouvelle grue de VICARIO

Una nueva grua de VICARIO

**VICARIO**

# OMV 45A

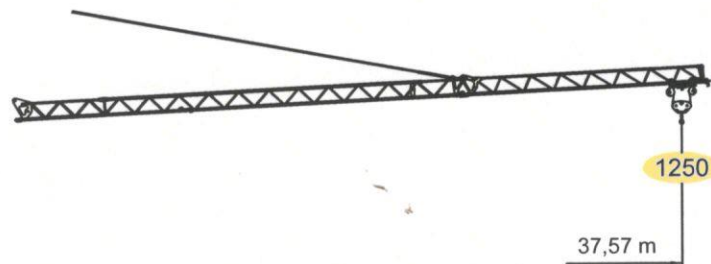
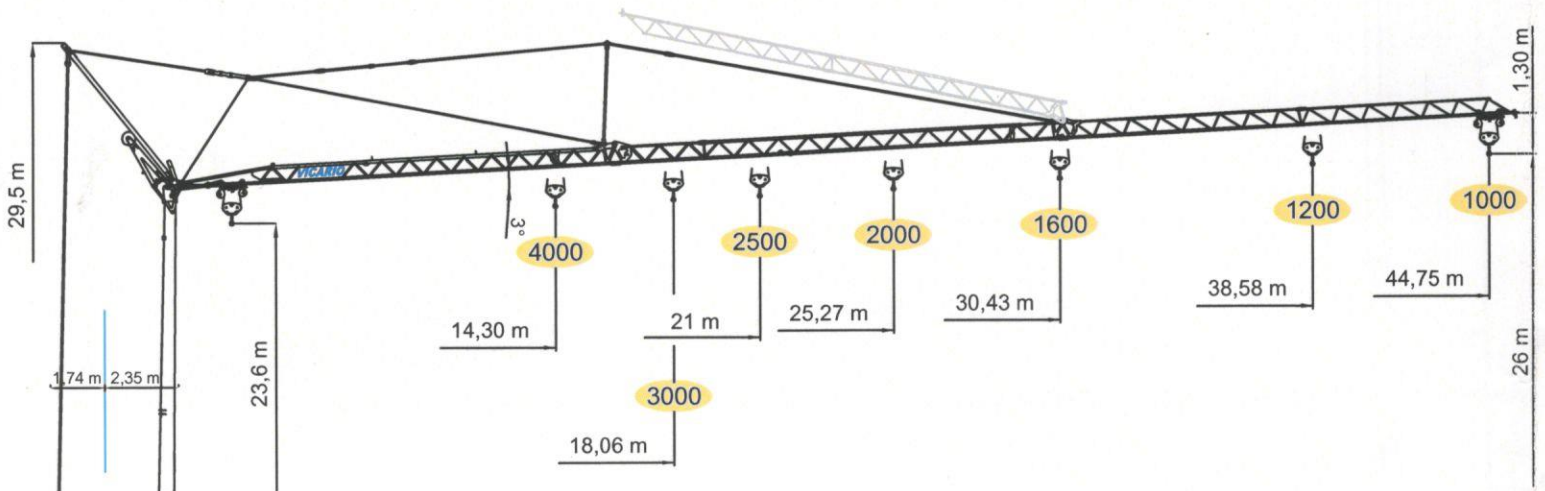
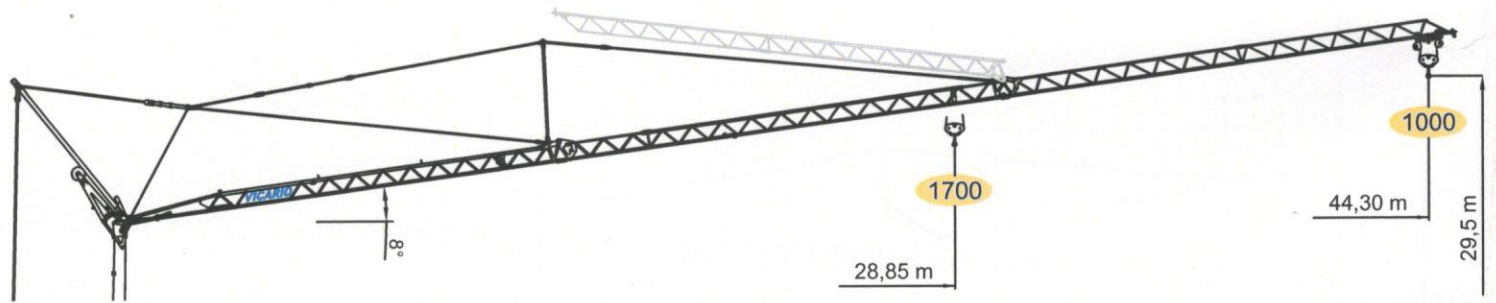
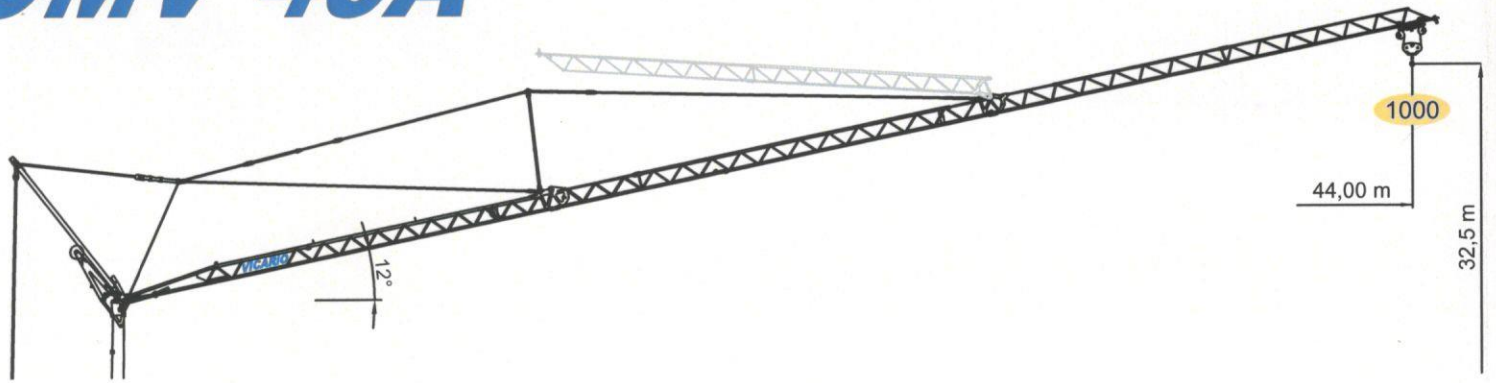

m	14,3	16	20	24	28	32	36	40	44,75
kg	4000	3480	2650	2130	1770	1505	1305	1150	1000







## DOTAZIONE DI SERIE

Sollevamento "overdrive" a quattro velocità con inverter, rotazione e carrello a tre velocità con inverter, zincatura della struttura e dei tiranti, contrappeso, braccio impennabile, carrello rampante con motore e finecorsa alla base della torre, funzionamento con braccio ripiegato, comando a pulsantiera via cavo, carter di protezione per ralla e meccanismi, predisposizione per autozavorramento e radiocomando, armadio elettrico in acciaio inox, documentazione a norme CEE.



## STANDARD FEATURES

4-speed lifting, 3-speed rotation and trolley with inverter control, galvanised structure, counterweight, pull-up jib, translation trolley with motor and limit switch at base of gantry, operation with folden jib, cable-operated pushbutton remote control, guard for slewing ring and mechanisms, designed to allow installation of self-ballasting device and radio control, stainless steel electrical cabinet, documentation in accordance with EU standards.



## EQUIPEMENT DE SERIE

Levage à quatre vitesses, chariot et rotation à trois vitesses à contrôle électronique, galvanisation de la structure et des tirants, contrepoids, flèche relevable, moteur de chariot et fin de course à la base de la tour, fonctionnement bras replié, commande par câble, carter de protection pour la couronne et les mécanismes, predisposition pour autolestage et commande radio, armoire électrique en acier inox, documentation conforme aux normes CEE.



## SERIENAUSSTATTUNG

Heben mit vier Geschwindigkeiten, Laufkatze und Rotation mit drei Geschwindigkeiten, Strukturverzinkung, Gegengewicht, hochklappbarer Arm, aufsteigender Wagen mit Motor und Anschlag an der Basis des Turms, Funktionieren mit eingeklapptem Arm, Steuerung mit Druckknopftaste via Kabel, Schutzvorrichtungen für Drehverbindungen und Mechanismen, Vorbereitung für Selbstballasteinahme und Funksteuerung, elektrischer Schrank aus rostfreiem Stahl, Dokumentation gemäß EC Vorschriften.



## DOTACION DE SERIE

Levantamiento a cuatro velocidades, carro y rotación a tres velocidades con control electrónico, galvanización de la estructura, contrapeso, brazo empuñable, carro rampante con motor y fin de carrera en la base de la torre, funcionamiento con brazo replgado, funcionamiento por pulsadores via cable, carter de protección para corona de giro y mecanismos, predisposición para autocontrapeso y radioccontrol, armario eléctrico de acero inox,

	400V (±10%) 50 Hz		18kVA		
	m/l'				
	kg	6,3	21	31	48
	kW	4000	4000	1400	1400
15 (Inverter)					
	m/l'				
	kg	17,8	28,6	53,5 (↗39,3)	
	kW	3 (Inverter)			
	n/l'				
	kg	0,13	0,29	0,58	
	kW	3,7 (Inverter)			
	min				
	kW	10	21740 kg		8.100 kg + 23.400 kg
	8100 kg	5400 kg	2700 kg	0 kg	
P1	13565 kg 14399 kg *	11363 kg 12171 kg *	9160 kg 9943 kg *	6957 kg 7715 kg *	
P2	16275 kg 15441 kg *	15777 kg 14969 kg *	15280 kg 14497 kg *	14783 kg 14025 kg *	

## OMV 45A

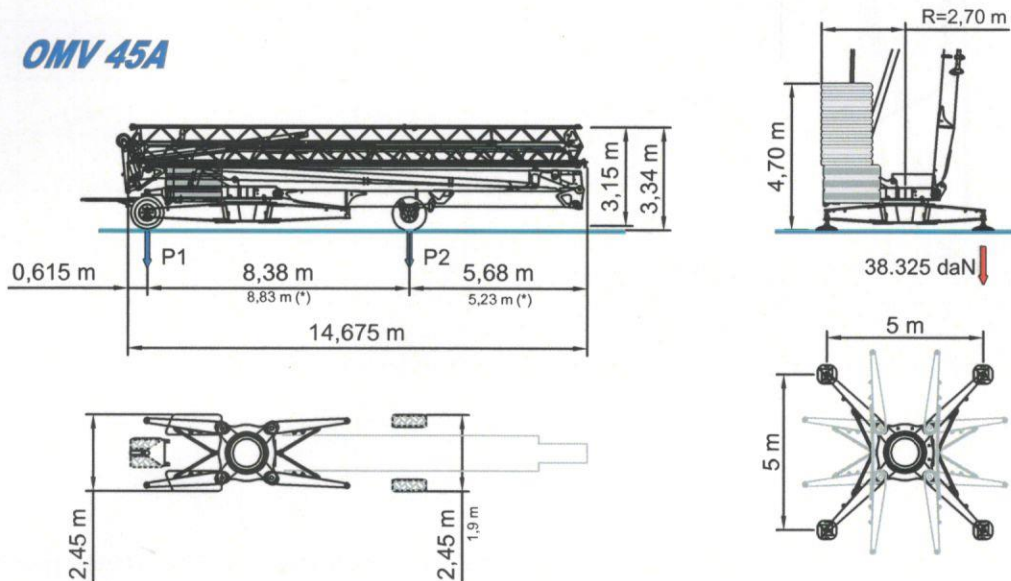

## OMV 45B

Variante a richiesta del cliente. Variation on request. Variation sur demande. Variation auf Anfrage. Variacion bajo petición.

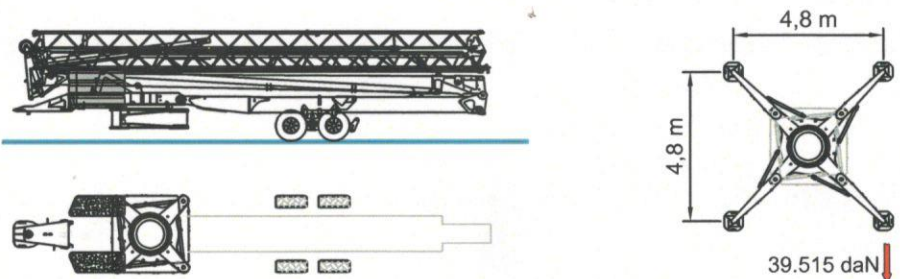



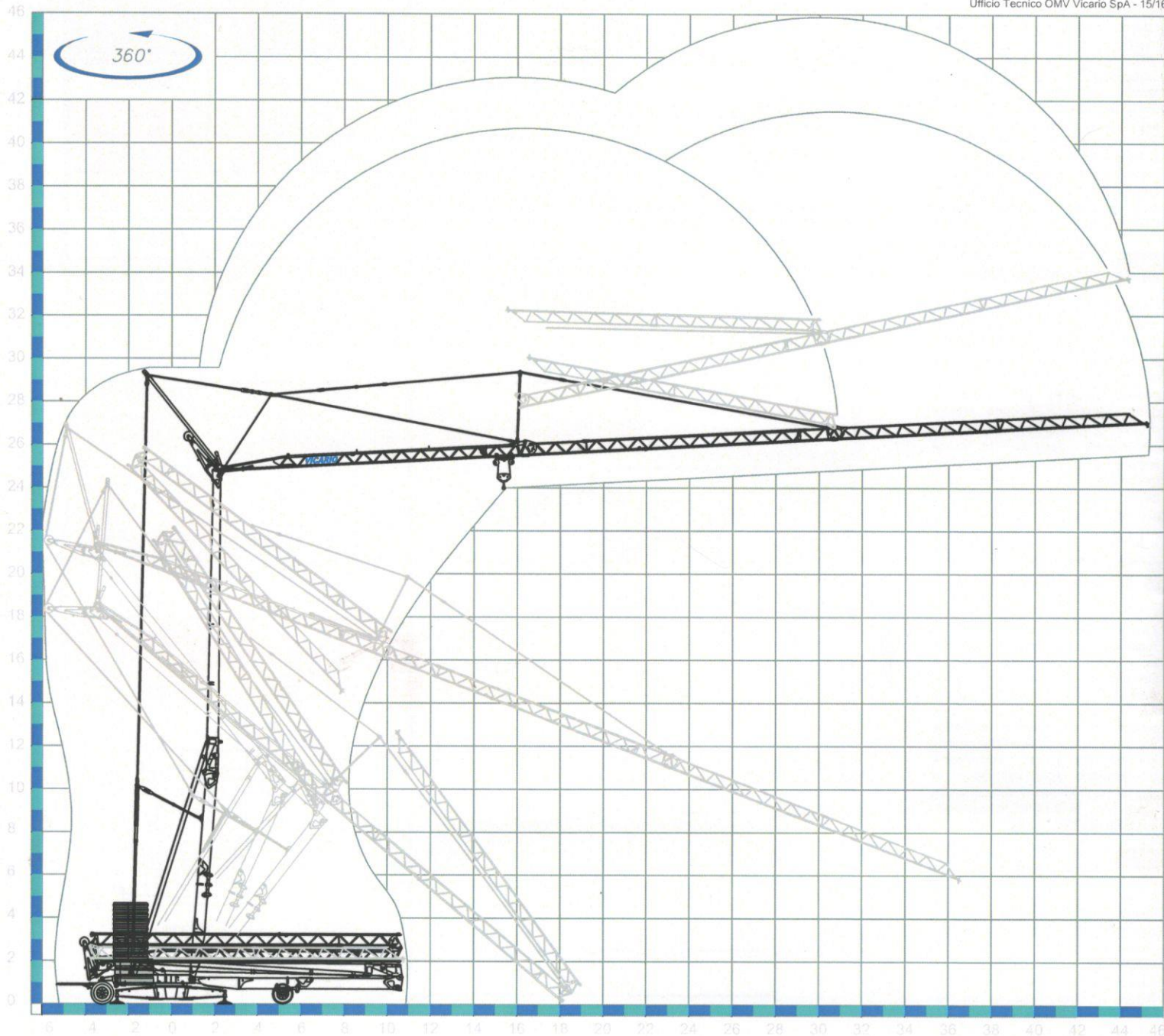

Sequenza di montaggio su 360°. Aufstellvorgang über 360°. Déroulement de montage sur 360°. Erection procedure on 360°. Montaje sobre 360°.

CRANES  
and  
TOOLS **VICARIO**  
**Officine Meccaniche Vicario S.p.a.**

Via Piola, 4

28013 Gattico (NO) ITALIA

Tel. 0322 846690 Fax 0322 846692

Internet: [www.vicariogru.com](http://www.vicariogru.com) E-Mail: [omv@vicariogru.com](mailto:omv@vicariogru.com)

Agente di zona: