

# PEINER SK 136/1

FEM 1001/3	A3
BGL 2125	0125
Max. Tragfähigkeit Lifting capacity Force de levage	8.0 t

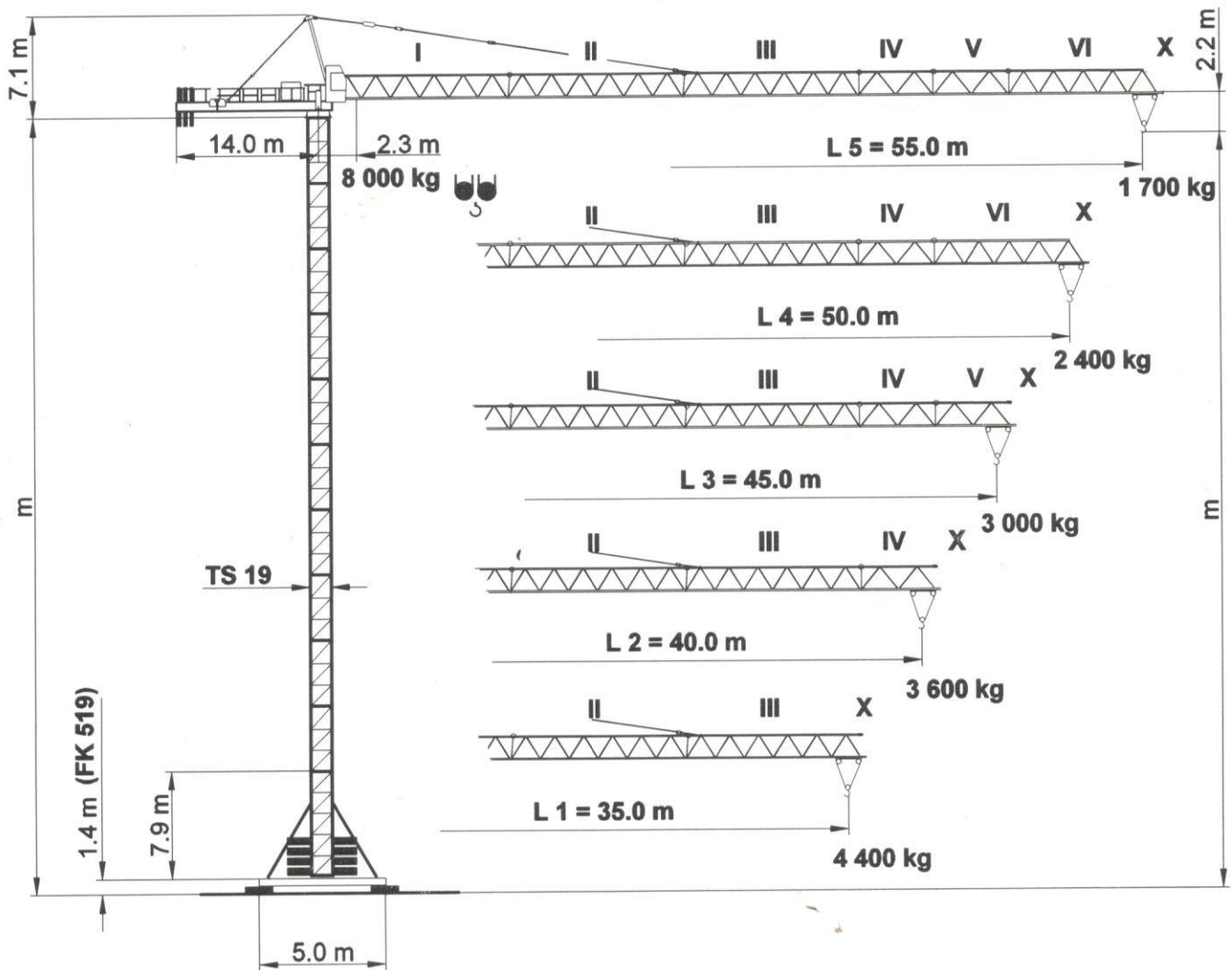

Unsere Vertretung:  
Our representative:  
Notre représentant:

# SK 136/1 Turmkombinationen, Hakenhöhen, Eckkräfte, Zentralballast

Combinations of tower section, hook heights, forces acting per corner, base ballast  
 Combinations possibles et hauteurs sous crochet, pressions par coin, contrepoids central

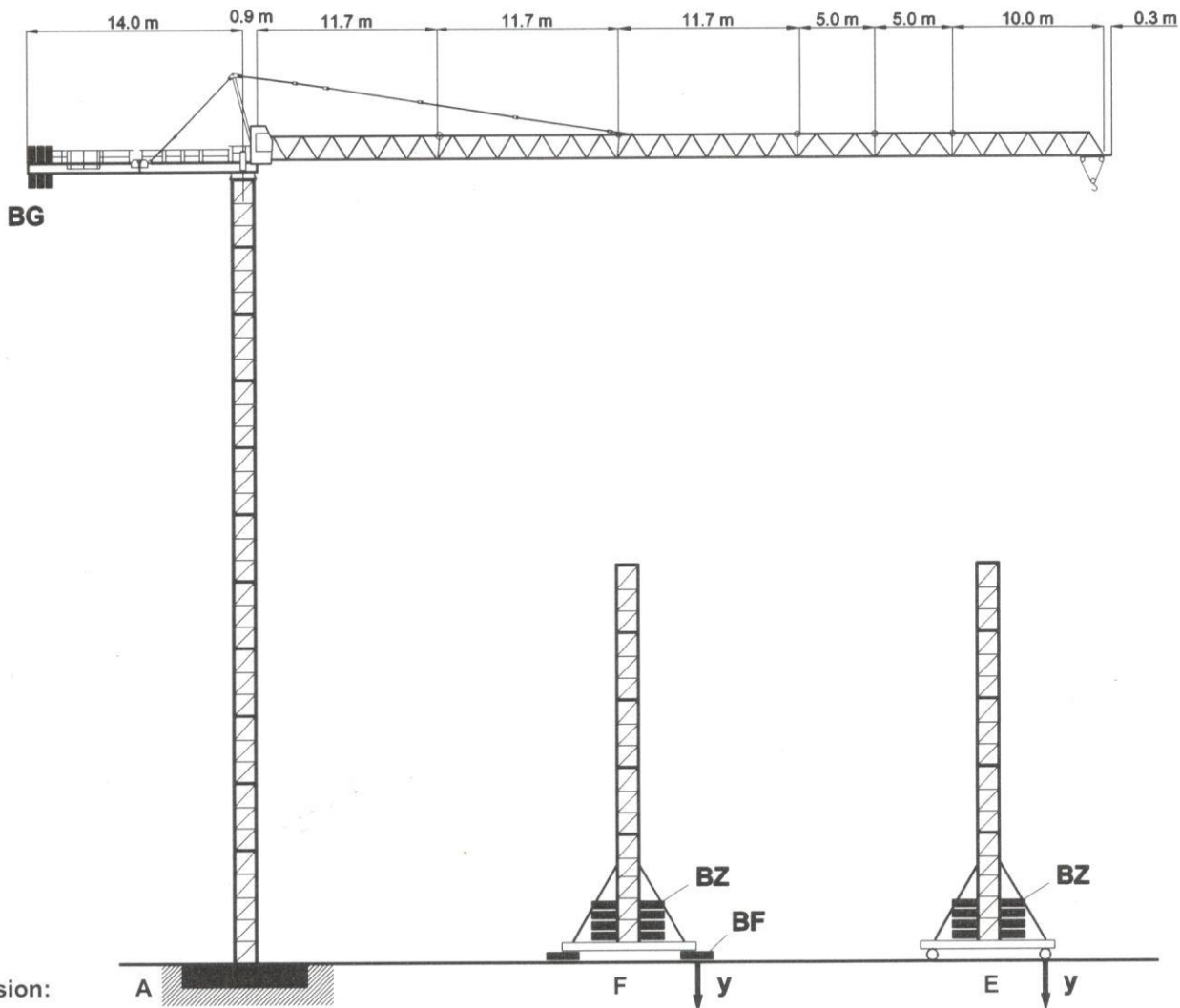

Version:

**FK 519 / 619**

**FKF 519 / 619**

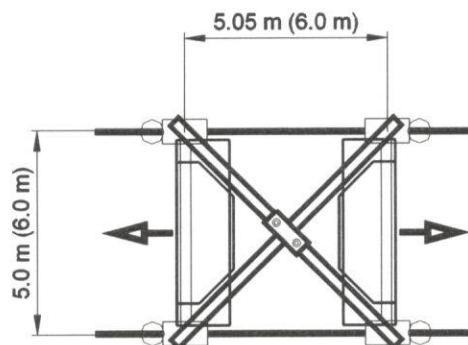
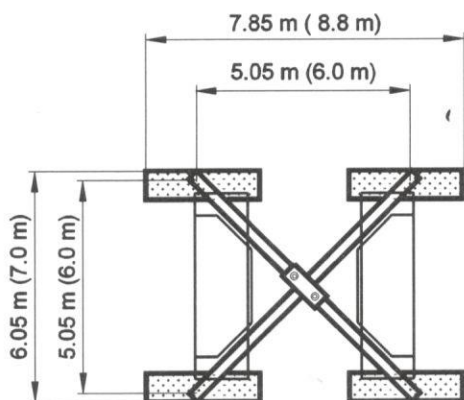

## Bodenauflagen

Ground support  
 Support sol

Version:

A

F

F / SP

E

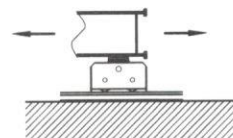
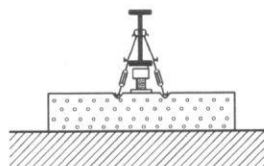
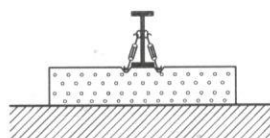
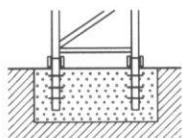

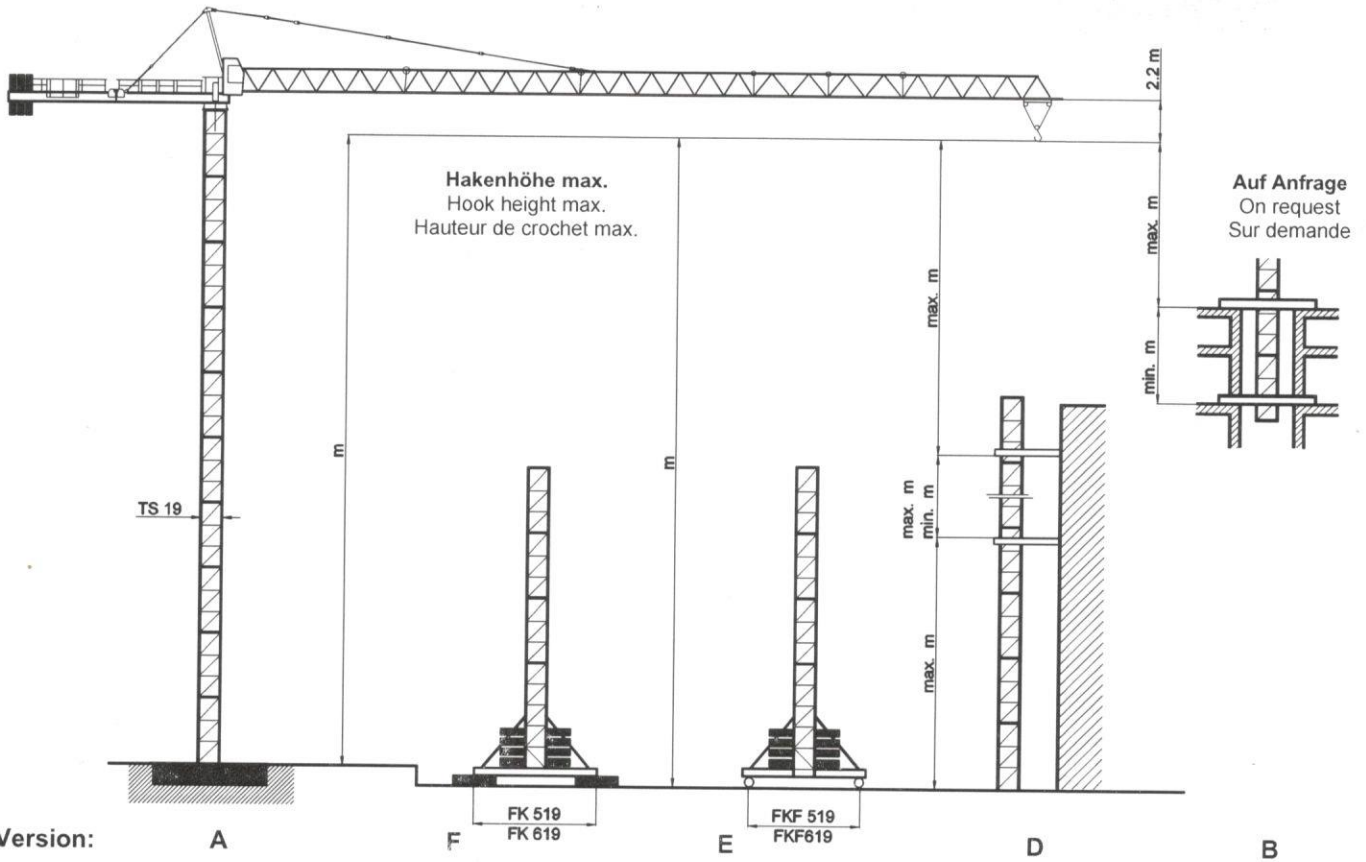

TS 19 Turm Tower, Tour TS 19.1	Version A		Version F						Version E						
	HK m	Turm Tower, Tour TSV 19.1 TS 19.1	HK m	BZ + BF t	i.B. kN	y kN	a.B. kN	BZ + BF t	i.B. kN	y kN	a.B. kN	BZ t	i.B. kN	y kN	a.B. kN
11 x TS 19.1		1 x TSV 19.1 10 x TS 19.1													
10 x TS 19.1		1 x TSV 19.1 9 x TS 19.1													
9 x TS 19.1		1 x TSV 19.1 8 x TS 19.1													
8 x TS 19.1		1 x TSV 19.1 7 x TS 19.1													
7 x TS 19.1		1 x TSV 19.1 6 x TS 19.1													
6 x TS 19.1		1 x TSV 19.1 5 x TS 19.1													
5 x TS 19.1		1 x TSV 19.1 4 x TS 19.1													
4 x TS 19.1		1 x TSV 19.1 3 x TS 19.1													
3 x TS 19.1		1 x TSV 19.1 2 x TS 19.1													
2 x TS 19.1		1 x TSV 19.1 1 x TS 19.1													
1 x TS 19.1		1 x TSV 19.1													
<b>Fundament</b> Foundation Fondaton  7.4 x 7.4 x 1.2 m			<b>Fundamentkreuz</b> Cruciform base Croix de fondation  FK 519			<b>Fundamentkreuz</b> Cruciform base Croix de fondation  FK 619			<b>Fundamentkreuz, kurvenfahrbar</b> Cruciform base, railgoing Croix de fondation, mobile  FKF 519			<b>Fundamentkreuz, kurvenfahrbar</b> Cruciform base, railgoing Croix de fondation, mobile  FKF 619			
<b>Fundamentfüße</b> Fixing angles Ancres de fondation  4 x FF 19			BF 4 x 4.0 t	BZ Block 5.0 t 6.1 t	BF 4 x 4.0 t	BZ Block 5.0 t 6.1 t	<b>Fahrschemel / bogie</b> Kurve / curve / courbe  F 500		<b>Fahrschemel / bogie</b> Kurve / curve / courbe  F 500						

TS 19.1 = 5.9 m

TSV 19.1 = 7.9 m

# SK 136/1 Ausladung und Tragfähigkeit / Radius and capacity / Portée et charge

Ausleger Jib Flèche  m	Max. Tragfähigkeit max. capacity charge max.  8.0 t	Ausladung (m) und Tragfähigkeit (t) Radius (m) and capacity (t) Portée (m) et charge (t)																	
		16	18	21	24	27	30	32	33	35	38	40	43	45	48	50	53	55	
L5 55.0	2.3 - 15.6 m	7.77	6.78	5.68	4.85	4.22	3.72	3.44	3.31	3.08	2.78	2.60	2.37	2.24	2.05	1.94	1.79	<b>1.70</b>	
L4 50.0	2.3 - 18.2 m	8.00	8.00	6.80	5.83	5.09	4.50	4.17	4.02	3.74	3.39	3.18	2.91	2.75	2.53	<b>2.40</b>			
L3 45.0	2.3 - 19.5 m	8.00	8.00	7.36	6.32	5.52	4.88	4.53	4.36	4.07	3.69	3.47	3.17	<b>3.00</b>					
L2 40.0	2.3 - 20.1 m	8.00	8.00	7.62	6.54	5.72	5.06	4.69	4.53	4.22	3.83	<b>3.60</b>							
L1 35.0	2.3 - 20.8 m	8.00	8.00	7.92	6.80	5.95	5.27	4.89	4.71	<b>4.40</b>									

## Geschwindigkeiten / Speeds / Vitesses

FU 4-80/4		$v =$	80 m / min.	4.0 kW	400 V 50 Hz 3 Ph
SR 8-130/3		$v = 0$	25 m / min.	2 x 7.5 kW	
K SRA 75/4		$v = 0$	0.75 min <sup>-1</sup>	2 x 6.0 kW	

HK max. = 120 m    3 - Lagen / 3 - layers / 3 - couches

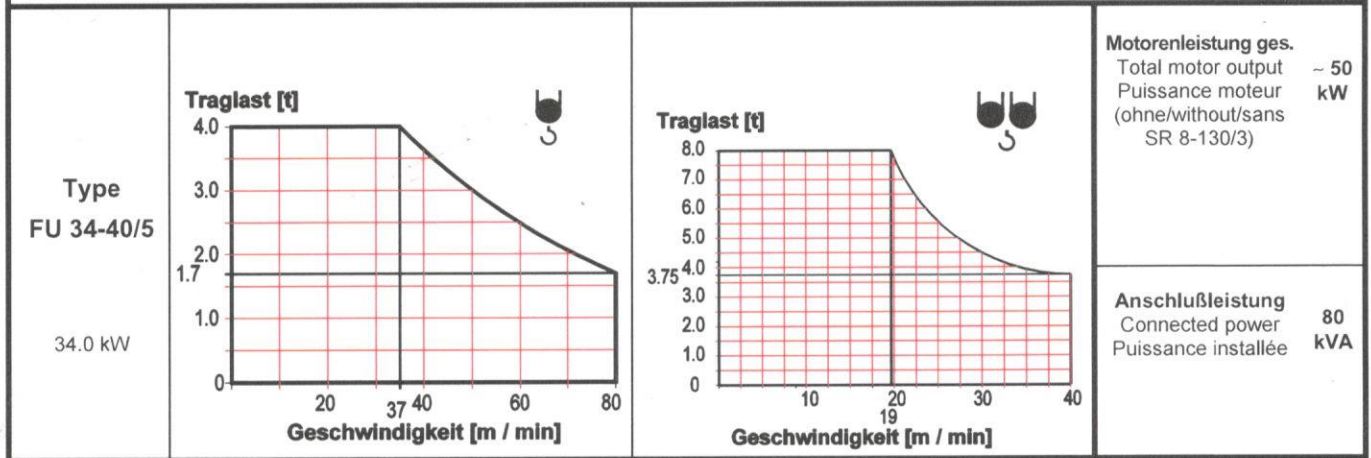

## Gegengewichtsballast / Counterweight / Contrepoids

Ausleger / Jib / Flèche		L 1	L 2	L 3	L 4	L 5
Gegengewicht Counterweight Contrepoids	BG	9 345 kg	10 450 kg	11 450 kg	11 450 kg	12 450 kg
	[t]	3 x 3.15	1 x 4.15 2 x 3.15	2 x 4.15 1 x 3.15	2 x 4.15 1 x 3.15	3 x 4.15 2 x 3.15



# SK 126/1; 136/1 Transportmaße und Transportgewichte

Dimensions and weights of transport  
Dimensions et poids pour transport

Montagegewichte siehe Betriebsanleitung!  
Mounting weights see operating manual!  
Poids de montage voir instruction de service!

	Benennung Designation Désignation		Abmessungen (m / ft) Dimensions (m / ft)			Gewicht Weight Poids t / kips	Volumen Volume m³ / ft³		
			l	b	h				
1	<b>Ausleger</b> / Jib / Flèche Schuss / Section / Élément I		11.95 39.21	1.38 4.53	2.66 8.73	2.90 6.39	41.3 1550		
2	<b>Ausleger</b> / Jib / Flèche Schuss / Section / Élément II		11.95 39.21	1.23 4.04	1.65 5.41	1.43 3.15	24.2 857		
	Schuss / Section / Élément III		11.95 39.21	1.23 4.04	1.87 6.14	1.37 3.02	27.4 973		
	Schuss / Section / Élément IV		5.19 17.03	1.25 4.10	1.65 5.41	0.37 0.82	10.7 377		
	Schuss / Section / Élément V		5.19 17.03	1.25 4.10	1.65 5.41	0.32 0.71	10.7 377		
	Schuss / Section / Élément VI		10.15 33.30	1.25 4.10	1.65 5.41	0.48 1.06	20.9 738		
	Seilstation / Jib tip / Bout de flèche X		0.59 1.94	1.23 4.04	0.47 1.54	0.08 0.18	0.4 12		
	3		<b>Drehbühne mit Drehkranzauflage u. Kabine</b> Turntable with slewing ring support and cabin Plateforme tournante avec support de couronne d'orientation et cabine		9.17 30.11	2.38 7.80	2.53 8.30	7.00 15.43	55.2 1949
4	<b>Drehbühne mit Drehkranzauflage</b> Turntable with slewing ring support Plateforme tournante avec support couronne d'orientation		8.17 26.80	2.38 7.80	2.53 8.30	5.30 11.68	49.2 1735		
5	<b>Kabine mit Podest und Geländer</b> Cabin with support and railing Cabine avec appui et garde corps		2.96 9.71	1.22 4.00	2.22 7.28	0.60 1.32	8.0 282		
6	<b>Hubwinde</b> Hoist winch Mécanisme de levage	FU 34		1.60 5.25	1.80 5.90	0.65 2.13	1.14 2.51	1.9 66	
7	<b>Gegengewichtsballast</b> Counter jib ballast Contrepoids	BG 4.15 t 3.15 t		1.20 3.94	0.50 1.64	3.69 12.11	4.15 9.1	2.2 78	
				1.20 3.94	0.50 1.64	2.84 9.32	3.15 6.9	1.7 60	
8	<b>Turmschuss</b> Tower section Élément de tour	TS 19.1		5.93 19.46	2.10 6.89	2.06 6.76	2.62 5.8	25.66 906	
		mit Streben, with struts, avec étançons TSV 19.1							
9	<b>Fundamentkreuz, fahrbar, geklappt</b> Movable undercarriage, folded Châssis roulant, replié	FKF 519		8.25 27.07	1.50 4.92	1.56 5.12	8.80 28.9	19.31 681	
		619							
10	<b>Fundamentkreuz, stationär, geklappt</b> Stationary undercarriage, folded Châssis fixe, replié	FK 519		7.58 24.87	1.36 4.46	0.95 3.11	5.40 11.9	9.80 345	
		619							
11	<b>Zentralballaststein</b> Central ballast block Bloc de fondation	BZ 6.1 t		4.00 13.12	1.35 4.43	0.65 2.13	6.10 13.4	3.5 124	
		5.0 t		3.50 11.48	1.50 4.92	0.67 2.20	5.00 11.2	3.5 124	
12	<b>Fundamentblock</b> Foundation pad Bloc de fondation	BF		2.80 9.19	0.70 2.30	0.55 1.80	2.70 5.9	1.08 38	
				2.80 9.19	1.00 3.28	0.57 1.87	4.00 8.82	1.60 57	
13	<b>Diverse Montageteile</b> Accessories Accessoires								